

GRANDE TARANTELLA

pianoforte

HERMAN RECHBERGER
AIGION GREECE 2020

♩ = 60

5

12

ff

sfz

8

7

12

ff

sfz

3

3

8

12

12

ff

sfz

8

15

12

ff

Presto ♩ = c. 136

41 3

48

53 3 4 5 6 7

58 8 9 10 11

63 12 13 14 15 16

68 17 18 19 20 21

p

mp

73 22 23 24 25 26

78 27 28 29 30 31

83 32 33 34 35 36

88 37 38 39 40 41

93 42

98 *sempre legatissimo*

103

mf

Musical score for measures 103-107. The system consists of two staves. The upper staff is in bass clef and contains a series of chords and melodic lines with slurs and accents. The lower staff is also in bass clef and features a more rhythmic accompaniment with slurs and accents. A dynamic marking of *mf* is present in the middle of the system.

108

f

Musical score for measures 108-111. The system consists of two staves. The upper staff is in bass clef and contains a series of chords and melodic lines with slurs and accents. The lower staff is also in bass clef and features a more rhythmic accompaniment with slurs and accents. A dynamic marking of *f* is present in the middle of the system.

112

Musical score for measures 112-115. The system consists of two staves. The upper staff is in treble clef and contains a series of chords and melodic lines with slurs and accents. The lower staff is also in treble clef and features a more rhythmic accompaniment with slurs and accents.

116

mf

Musical score for measures 116-119. The system consists of two staves. The upper staff is in treble clef and contains a series of chords and melodic lines with slurs and accents. The lower staff is also in treble clef and features a more rhythmic accompaniment with slurs and accents. A dynamic marking of *mf* is present in the middle of the system.

120

Musical score for measures 120-123. The system consists of two staves. The upper staff is in treble clef and contains a series of chords and melodic lines with slurs and accents. The lower staff is also in treble clef and features a more rhythmic accompaniment with slurs and accents.

124

Musical score for measures 124-127. The system consists of two staves. The upper staff is in treble clef and contains a series of chords and melodic lines with slurs and accents. The lower staff is also in treble clef and features a more rhythmic accompaniment with slurs and accents.

128 *mf* *f*

132

136 *sf*

140 *mf* RH LH *mf*

144

148 *f* RH

155

mf

Musical score for measures 155-158. The piece is in 3/4 time with a key signature of one flat (B-flat major). Measure 155 starts with a treble clef and a dynamic marking of *mf*. The bass line begins in measure 156. The music features eighth-note patterns in the treble and quarter notes in the bass.

159

mp

Musical score for measures 159-162. The music continues with a dynamic marking of *mp*. Measures 160-162 feature a prominent four-measure chordal pattern in the treble, with the bass line providing a steady accompaniment.

163

Musical score for measures 163-166. The treble clef is introduced in measure 163. The piece continues with the four-measure chordal pattern in the treble and a rhythmic bass line.

167

Musical score for measures 167-170. The music continues with the four-measure chordal pattern in the treble and a rhythmic bass line.

171

p

Musical score for measures 171-180. Measures 171 and 172 feature a whole rest in the treble, with the number '17' written above the staff. The bass line continues with a rhythmic pattern. A dynamic marking of *p* is present in measure 172. The piece concludes in measure 180 with a final chord.

191

Musical score for measures 191-194. The music continues with a rhythmic bass line and chords in the treble.

195

9

mp

p

207

211

mp

215

219

mf

f

223

3

mf

3

229

233

237

241

245

249

mf

253

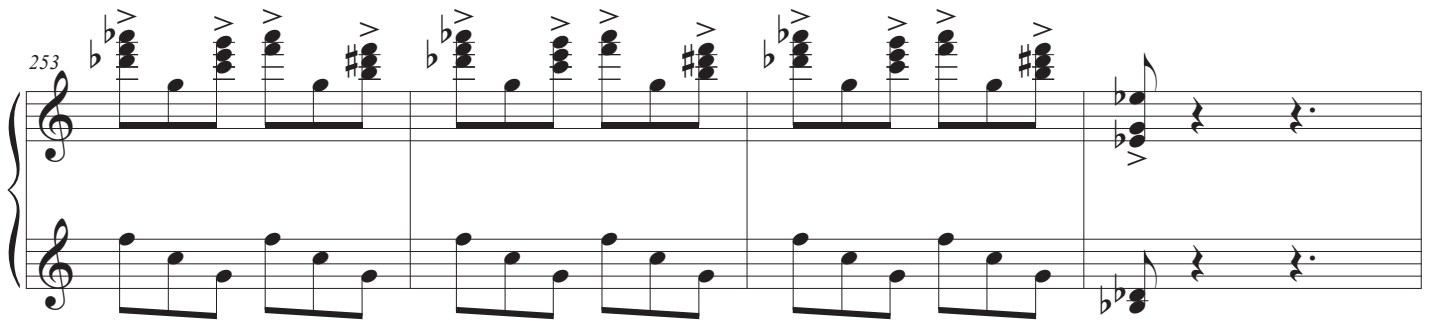

257

sfz

30 9

30 9

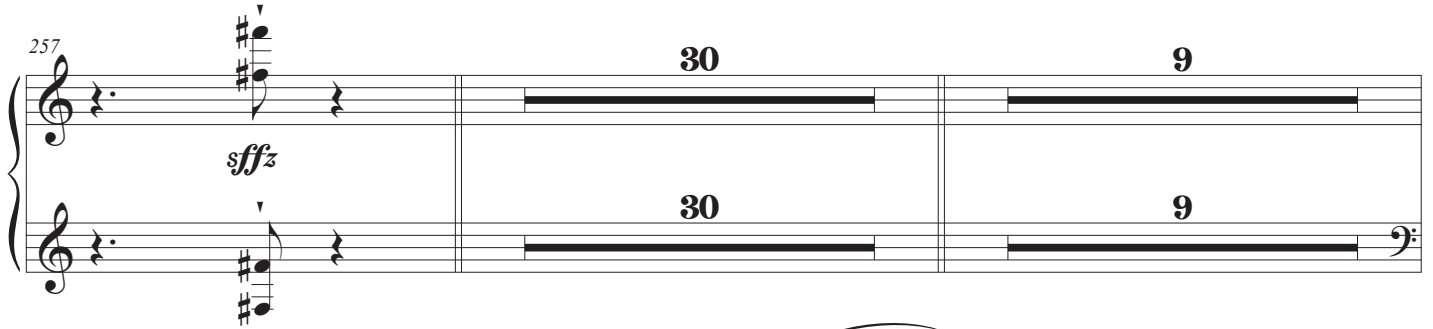

297

10 10

mf



299

10 10

mf

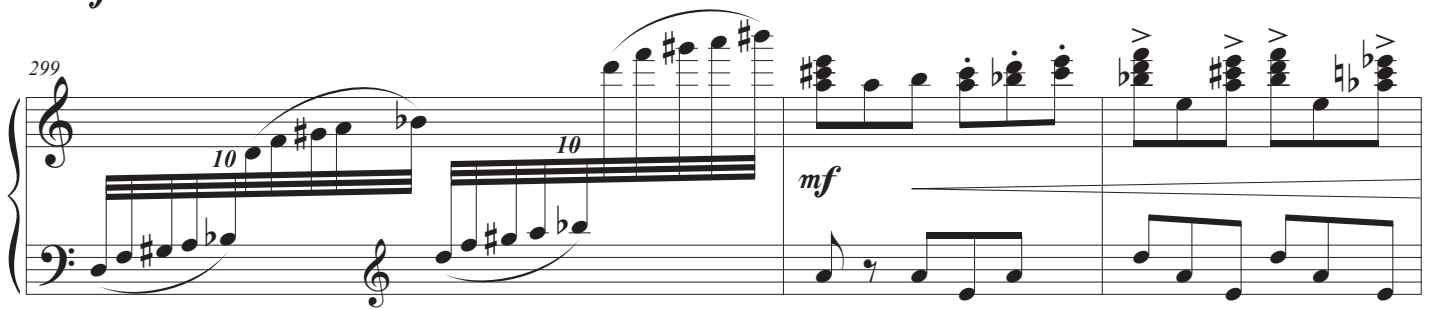

302

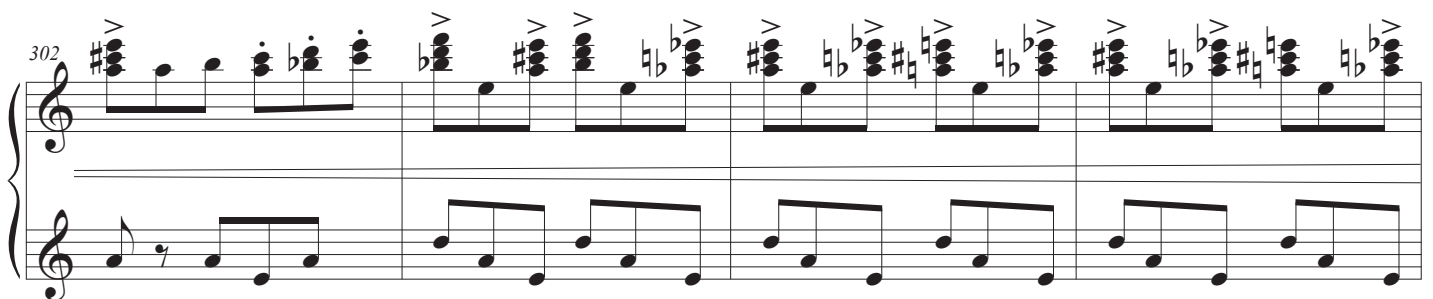

306

sfz

sfz *ff*



310

30

30

mf

343

348

mf

mf

354

mf

360

366

372

Musical score for measures 372-377. The right hand plays chords with a sharp sign, and the left hand plays a rhythmic pattern of eighth notes.

378

Musical score for measures 378-383. The right hand continues with chords, and the left hand continues with eighth notes.

384

Musical score for measures 384-396. Measure 384 has a "9" above the staff. The right hand has a long note with a slur. The left hand has a "p" dynamic marking.

397

Musical score for measures 397-401. The right hand has a long note with a slur. The left hand has a "mf" dynamic marking.

402

Musical score for measures 402-406. The right hand has a long note with a slur. The left hand has a "mf" dynamic marking.

407

Musical score for measures 407-411. The right hand has a long note with a slur. The left hand has a "mf" dynamic marking.

411

Musical score for measures 411-415. The system consists of two staves. The upper staff is in bass clef and contains a melodic line with a long slur over measures 411-415. The lower staff is in bass clef and contains a harmonic accompaniment. Measure 411 starts with a whole rest in the upper staff. The key signature has one flat and one sharp.

416

Musical score for measures 416-420. The system consists of two staves. The upper staff is in bass clef and contains a melodic line with a long slur over measures 416-420. The lower staff is in bass clef and contains a harmonic accompaniment. Measure 416 starts with a whole rest in the upper staff. The key signature has one flat and one sharp.

421

Musical score for measures 421-425. The system consists of two staves. The upper staff is in bass clef and contains a melodic line with a long slur over measures 421-425. The lower staff is in bass clef and contains a harmonic accompaniment. Measure 421 starts with a whole rest in the upper staff. The key signature has one flat and one sharp. At the end of the system, there is a dynamic marking *mp* and a time signature change to 8:6.

428

Musical score for measures 428-432. The system consists of two staves. The upper staff is in treble clef and contains a melodic line with a long slur over measures 428-432. The lower staff is in treble clef and contains a harmonic accompaniment. Measure 428 starts with a whole rest in the upper staff. The key signature has one flat and one sharp. Time signatures 8:6 and 9:6 are indicated.

426

Musical score for measures 426-430. The system consists of two staves. The upper staff is in treble clef and contains a melodic line with a long slur over measures 426-430. The lower staff is in treble clef and contains a harmonic accompaniment. Measure 426 starts with a whole rest in the upper staff. The key signature has one flat and one sharp. Time signatures 9:6 and 8:6 are indicated.

428

Musical score for measures 428-432. The system consists of two staves. The upper staff is in treble clef and contains a melodic line with a long slur over measures 428-432. The lower staff is in treble clef and contains a harmonic accompaniment. Measure 428 starts with a whole rest in the upper staff. The key signature has one flat and one sharp. Time signatures 8:6 and 8 are indicated.

438

8:6

8:6

433

martellato

f

14

14

sf

sf

450

sf

sf

sf

12

12

463

mf

469

473

478

43

43

528

mp

526

23

23

551

f

555

560

ff

566

p *mp*

8

This system contains five measures of music. The upper staff begins with a treble clef and a key signature of one sharp (F#). It features a melodic line with eighth notes and a bass line with dotted quarter notes. The lower staff continues the bass line with eighth notes. Dynamic markings *p* and *mp* are present. A fermata is placed over the eighth note in the first measure of the lower staff.

571

8

This system contains five measures of music. The upper staff has a bass clef and continues the melodic line with dotted quarter notes. The lower staff continues the bass line with eighth notes.

576

8

This system contains five measures of music. The upper staff has a bass clef and continues the melodic line with dotted quarter notes. The lower staff continues the bass line with eighth notes.

581

mf

8

This system contains six measures of music. The upper staff has a bass clef and continues the melodic line with dotted quarter notes. The lower staff continues the bass line with eighth notes. A fermata is placed over the first measure of the upper staff. The key signature changes to one flat (Bb) in the final two measures.

587

This system contains six measures of music. The upper staff has a bass clef and continues the melodic line with dotted quarter notes. The lower staff continues the bass line with eighth notes.

593

This system contains six measures of music. The upper staff has a bass clef and continues the melodic line with dotted quarter notes. The lower staff continues the bass line with eighth notes.

599

Two staves of musical notation for measures 599-604. The upper staff is in bass clef and contains a single melodic line with notes G2, A2, B2, C3, D3, E3, F3, G3, A3, B3, C4, D4, E4, F4, G4, A4, B4, C5. The lower staff contains a rhythmic accompaniment of eighth and sixteenth notes.

605

Two staves of musical notation for measures 605-610. The upper staff continues the melodic line from the previous system. The lower staff continues the rhythmic accompaniment.

611

Two staves of musical notation for measures 611-616. Measures 611-614 continue the previous pattern. Measures 615 and 616 feature a more complex melodic line in the upper staff with slurs and accidentals.

617

Two staves of musical notation for measures 617-622. Measures 617-621 feature a complex melodic line in the upper staff with multiple slurs and accidentals. The lower staff continues the rhythmic accompaniment.

623

Two staves of musical notation for measures 623-628. Measures 623-627 feature a complex melodic line in the upper staff with multiple slurs and accidentals. The lower staff continues the rhythmic accompaniment.

629

Two staves of musical notation for measures 629-634. Measures 629-633 feature a complex melodic line in the upper staff with multiple slurs and accidentals. The lower staff continues the rhythmic accompaniment.

634

639

ff

15

15

657

f

4

663

martellato

667

martellato

671

675

glissando
mf 15

681

mp 15 15

684

15 10 4 *f* 10 4

697

2 4 4 2 4

701

2 4 4 2 4

705

5 *fff* 9 *ff* 5 4 9 3